



**Bicycles carrier** EN  
Installation and usage instructions

**Fahrradträger** DE  
Montage- und Gebrauchsanleitung

**Porte-vélos** FR  
Instructions de montage et mode d'emploi

**Portabicicletas** ES  
Instrucciones de montaje y uso

**Portabici** IT  
Istruzioni di montaggio e d'uso

**Fietsendrager** NL  
Montage- en gebruiksinstructies

**Cykelhållare** SV  
Monterings- och bruksanvisning

**Cykelholder** DA  
Monterings- og brugsvejledning

**Sykelstativ** NO  
Monterings- og bruksinstruksjoner

**Pyöräteline** FI  
Asennus- ja käyttöohjeet

**Porta-bicicletas** PT  
Instruções de montagem e de uso

## CARRY-BIKE

**200 D**  
**02093-15-**



CARRY-BIKE

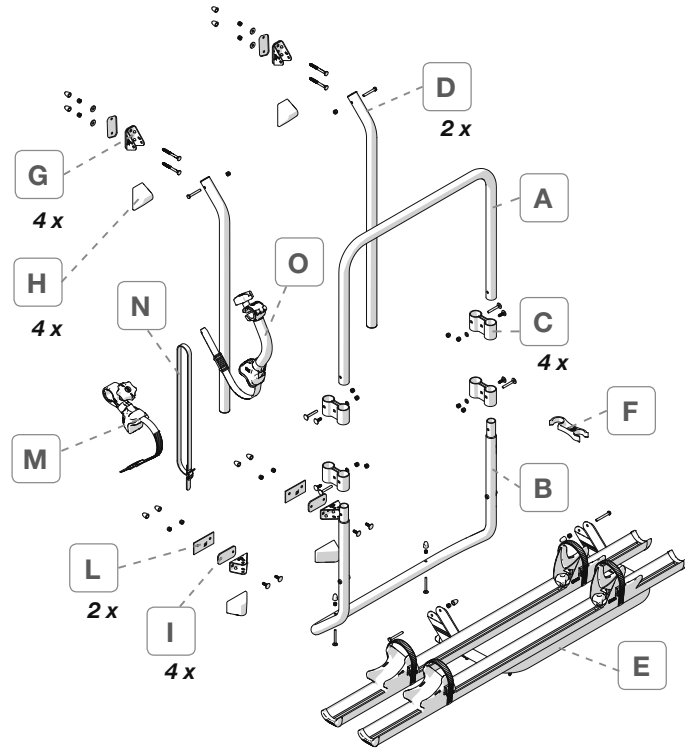

M6x20 8 x Q M6x45 4 x R M6x65 4 x P M5x50 2 x V M6x50 2 x S M6x45 2 x T

6,4 x 12,5 4 x U 6,5 x 18 4 x W M5 2 x Y M5 2 x K M6 20 x X M6 10 x Z

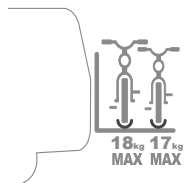

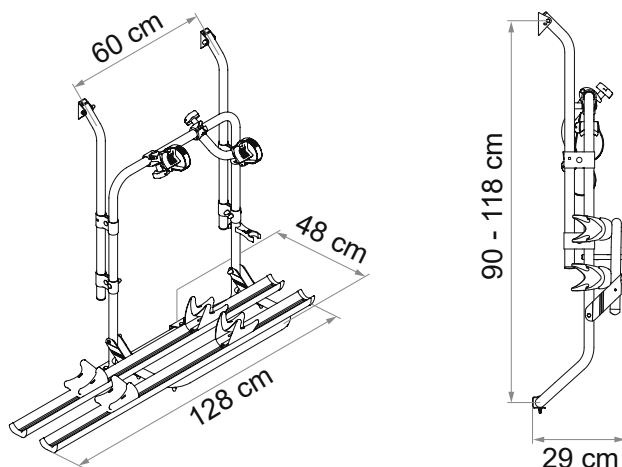

Package contents / Verpackungsinhalt / Contenu de l'emballage / Contenido del embalaje /  
Contenuto dell'imballo / Inhoud van de verpakking / Förpackningens innehåll / Pakkens indhold /  
Innholdet i pakningen / Pakkauksen sisältö / Conteúdo da embalagem **p. 2**

Installation instructions / Montageanleitung / Instructions de montage / Instrucciones de montaje /  
Istruzioni di montaggio / Montage-instructies / Monteringsanvisningar / Monteringsvejledning /  
Monteringsinstruksjoner / Asennusohjeet / Instruções de montagem **p. 5**

Instructions for use / Gebrauchsanleitung / Instructions d'installation / Instrucciones de uso /  
Istruzioni di utilizzo / Gebruiksaanlecties / Bruksanvisning / Brugsvejledning / Bruksinstruksjoner /  
Käyttöohjeet / Instruções de utilização **p. 10**

Safety instructions / Sicherheitshinweise / Consignes de sécurité / Instrucciones de seguridad /  
Avvertenze di sicurezza / Veiligheidswaarschuwingen / Säkerhetsföreskrifter / Sikkerhedsforan-  
staltninger / Sikkerhedsadvarsler / Turvallisuusvaroitukset / Advertências de segurança **p. 11**

Accessories / Zubehör / En option / Accesorios / Accessori / Benodigdheden / Tillbehör /  
Tilbehør / Tilbehør / Lisävarusteet / Acessórios **p. 23**

Warranty / Garantie / Garantie / Garantía / Garanzia / Garantie / Garanti / Garanti / Garanti /  
Takuu / Garantia **p. 23**



- EN** Check that nothing has been damaged or deformed during transport.  
In the event of doubts or questions concerning the installation, use or limitations of the product, contact the dealer.  
We recommend that the installation is carried out by qualified personnel and in compliance with current local regulations.
- DE** Bitte kontrollieren Sie, dass alle Einzelteile einwandfrei sind und nicht während dem Transport beschädigt wurden.  
Im Zweifelsfall oder bei Fragen zur Montage, Verwendung oder zu Einschränkungen des Produkts wenden Sie sich bitte an Ihren Händler.  
Wir empfehlen die Anbringung durch Fachpersonal in Übereinstimmung mit den geltenden lokalen Vorschriften vornehmen zu lassen.
- FR** Contrôler le contenu du colis et vérifier qu'aucune pièce n'ait été cassée ou déformée durant le transport.  
En cas de doutes ou de questions relatives à l'installation, l'utilisation et les limitations du produit, contactez votre concessionnaire.  
L'installation doit être réalisée par des personnes dûment qualifiées et conformément aux normes en vigueur dans le pays d'installation.
- ES** Controlar que ningún detalle se haya roto o deformado durante el transporte.  
En caso de dudas o si tiene alguna pregunta sobre el montaje, uso y limitaciones del producto, póngase en contacto con el distribuidor.  
Recomendamos que la instalación se realice por personal cualificado en conformidad con las regulaciones locales.
- IT** Controllare che nessun particolare sia rotto o deformato a causa di errori di trasporto.  
In caso di dubbi o domande relative al montaggio, utilizzo e limiti del prodotto, contattare il rivenditore.  
Consigliamo di far eseguire l'installazione da parte di personale qualificato ed in conformità alle vigenti normative locali.
- NL** Controleer of er geen onderdelen zijn gebroken of vervormd als gevolg van het transport.  
Neem contact op met uw dealer als u vragen of opmerkingen hebt over de montage, het gebruik en de beperkingen van het product.  
Wij raden u aan de montage te laten uitvoeren door gekwalificeerd personeel en in overeenstemming met de geldende plaatselijke voorschriften.
- SV** Kontrollera att inga delar har skadats eller deformerats under transporten.  
Kontakta försäljaren om du har frågor om monteringen, användningen och produktens gränser.  
Vi rekommenderar att kvalificerad personal utför installationen i överensstämmelse med gällande lokala standarder.
- DA** Kontrollér, at ingen del er ødelagt eller deformeret grundet fejl under transport.  
I tvivlstilfælde, eller hvis du har spørgsmål vedrørende montering eller produktets brug og begrænsninger, bedes du kontakte forhandleren.  
Vi anbefaler, at monteringen udføres af kvalificeret personale og i overensstemmelse med gældende lokale regler.
- NO** Kontroller at ingen deler er ødelagt eller deformert som følge av feil under transporten.  
Hvis du er i tvil eller har spørsmål knyttet til montering, bruk eller begrensninger for produktet, ta kontakt med forhandleren.  
Vi anbefaler at installasjonen gjennomføres av kvalifisert personale og i samsvar med gjeldende lokale regler.
- FI** Tarkasta, että mikään osa ei ole kuljetusvirheiden vuoksi rikkoutunut tai vääntynyt.  
Epäselvissä tapauksissa tai jos sinulla on tuotteen asennusta, käyttöä tai rajoituksia koskevia kysymyksiä, ota yhteys jälleenmyyjään.  
Anna asennus tehtäväksi ammattitaitoiselle henkilöstölle ja siinä on noudatettava paikallisia voimassa olevia määräyksiä.
- PT** Controlar que nenhuma peça tenha ficado partida ou deformada devido a erros de transporte.  
Em caso de dúvida ou perguntas relativas à montagem, utilização e limites do produto, contactar o revendedor.  
Aconselhamos a fazer executar a instalação por pessoal qualificado e em conformidade com as normas locais em vigor.

1

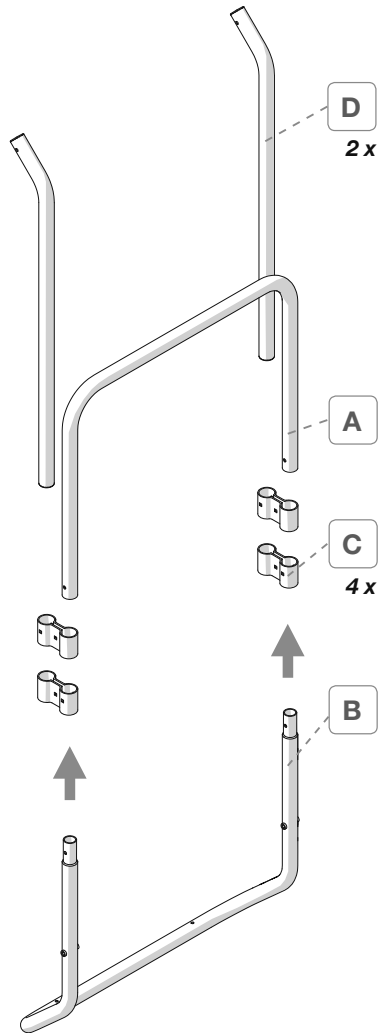

2

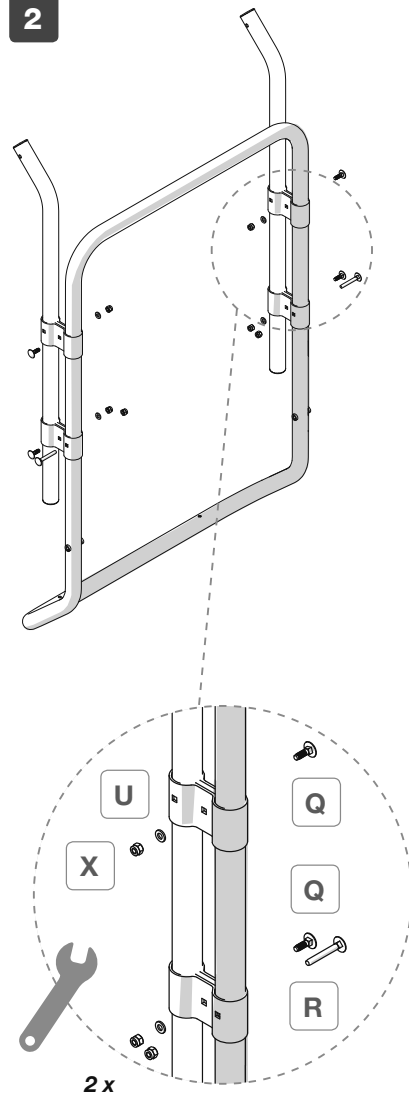

5



3

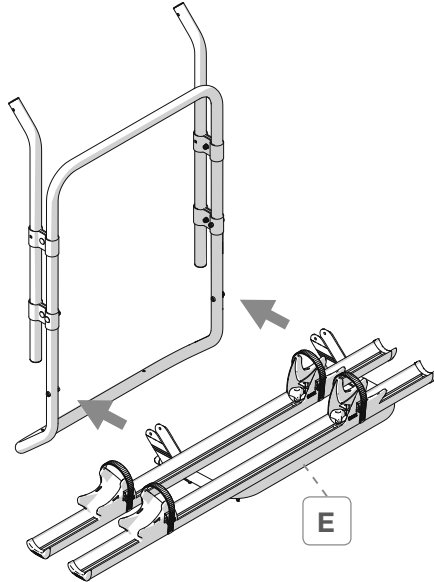

4

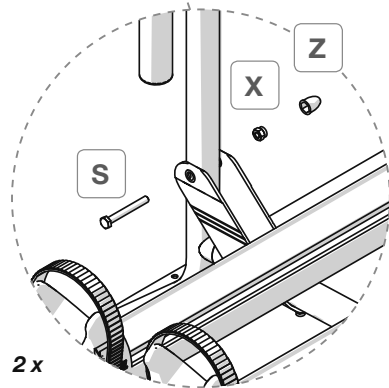
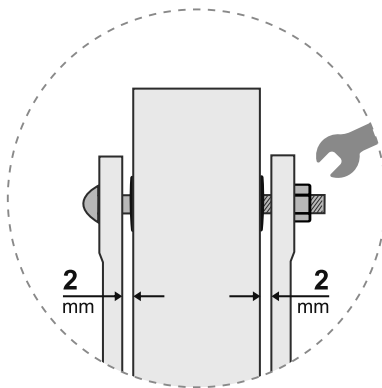
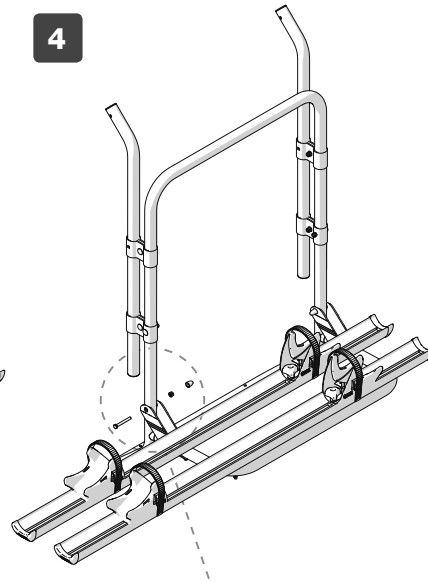

**WARNING!** Do not fully tighten the fork to the tube, leave 2 mm space.

**ACHTUNG!** Die Gabel nicht komplett am Rohr festziehen, 2 mm Abstand lassen

**ATTENTION!** Ne pas serrer complètement la fourche au tube, laisser un espace de 2 mm.

**ADVERTENCIA!** No apretar totalmente la horquilla al tubo, dejar 2 mm de espacio.

**ATTENZIONE!** Non stringere completamente la forcella al tubo, lasciare 2 mm di spazio.

**OPGELET!** Draai de vork niet helemaal vast op de buis, laat 2 mm ruimte vrij.

**VARNING!** Dra inte åt gaffeln till röret helt och hållet, lämna ett utrymme på 2 mm.

**ADVARSEL!** Stram ikke gafflen helt til røret. Efterlad et mellemrum på 2 mm.

**ADVARSEL!** Ikke stram gaffelen helt til røret, la det være et mellomrom på 2 mm.

**HUOMIO!** Älä kiristä haarukkaa kokonaan putkeen, jätä 2 mm tilaa.

6 **ATENÇÃO!** Não apertar completamente a forquilha ao tubo, deixar 2 mm de espaço.

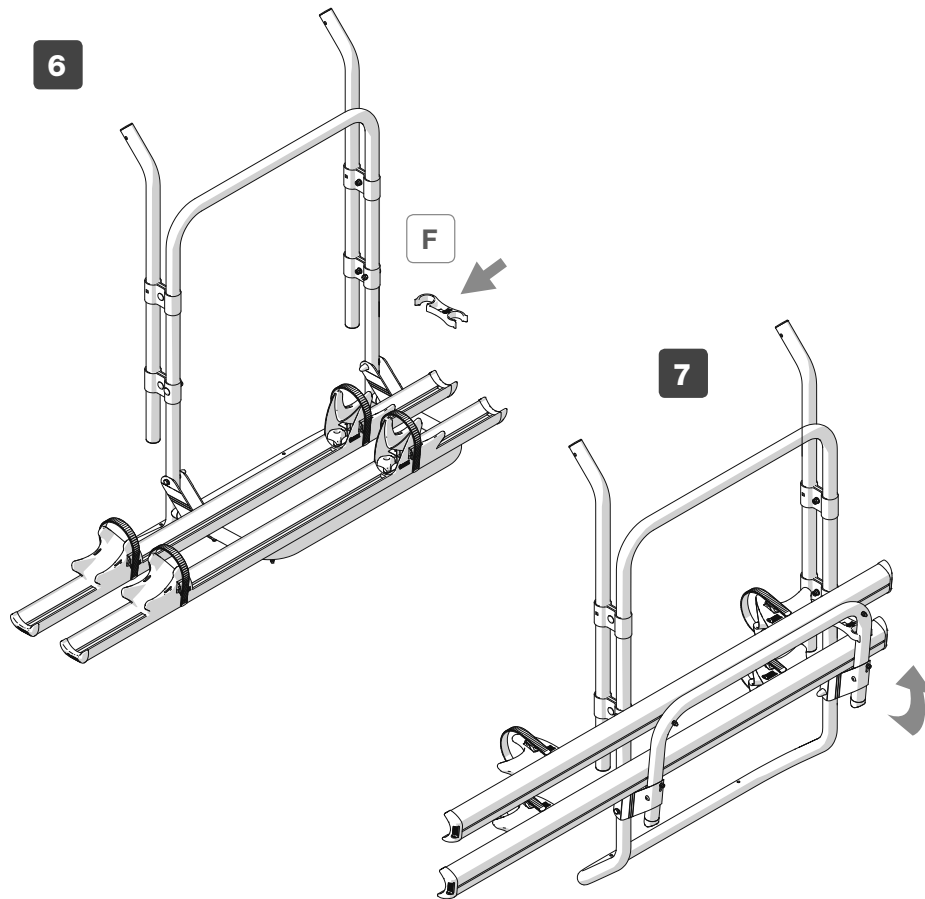
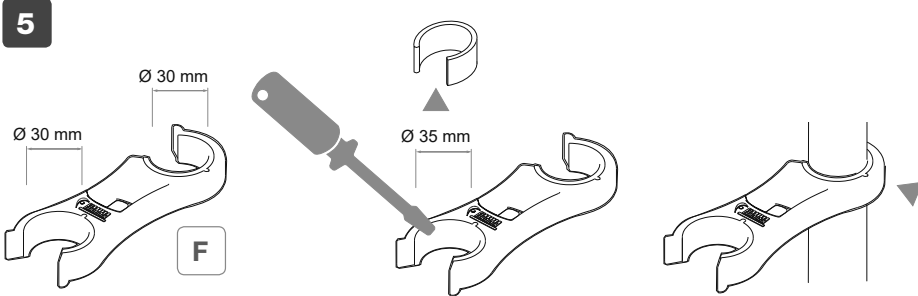

CARRY-BIKE

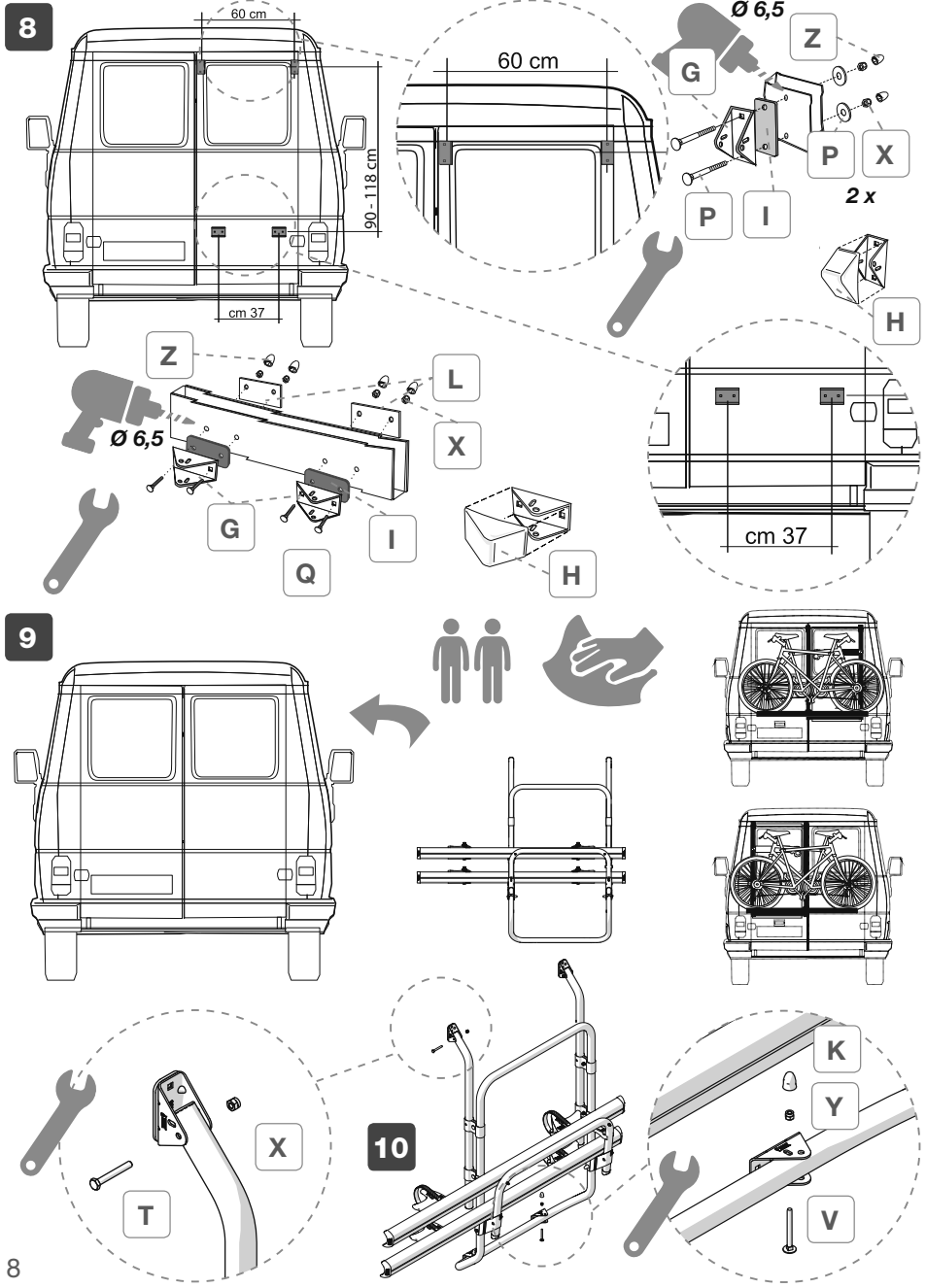

8

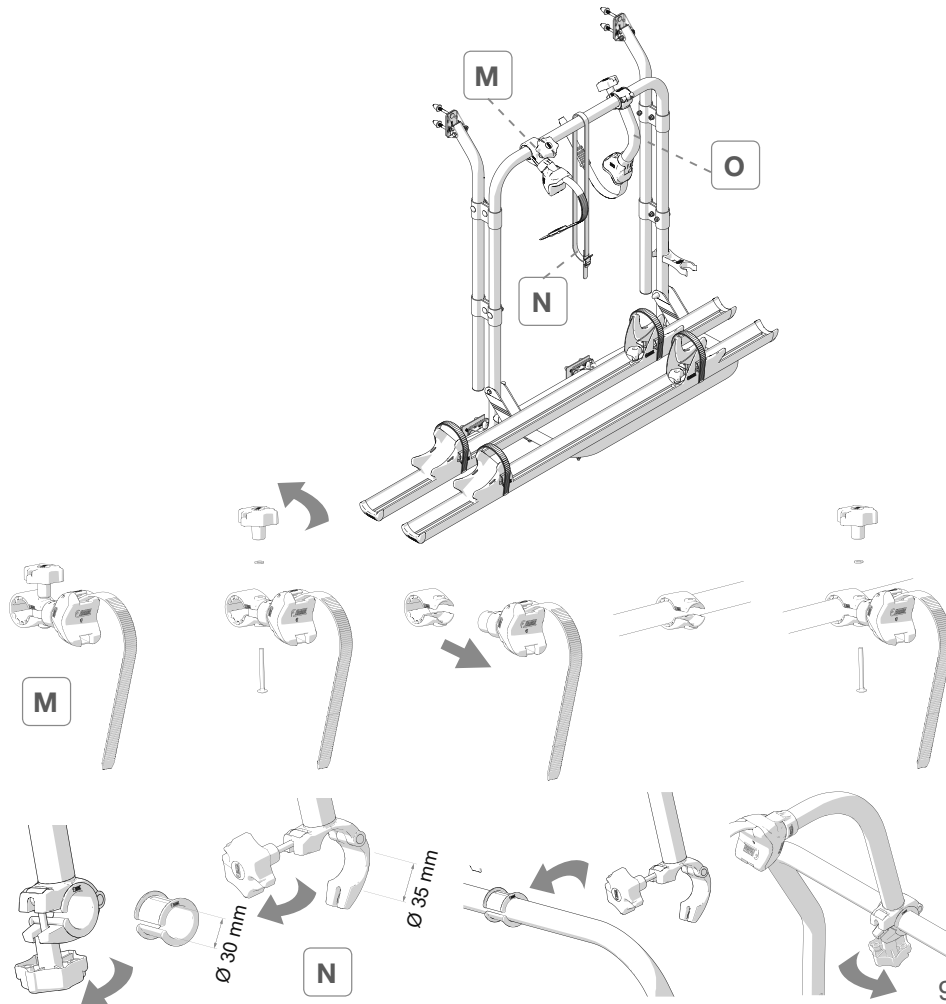
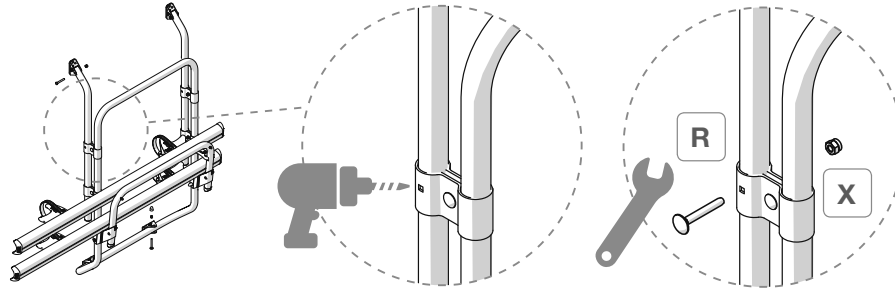

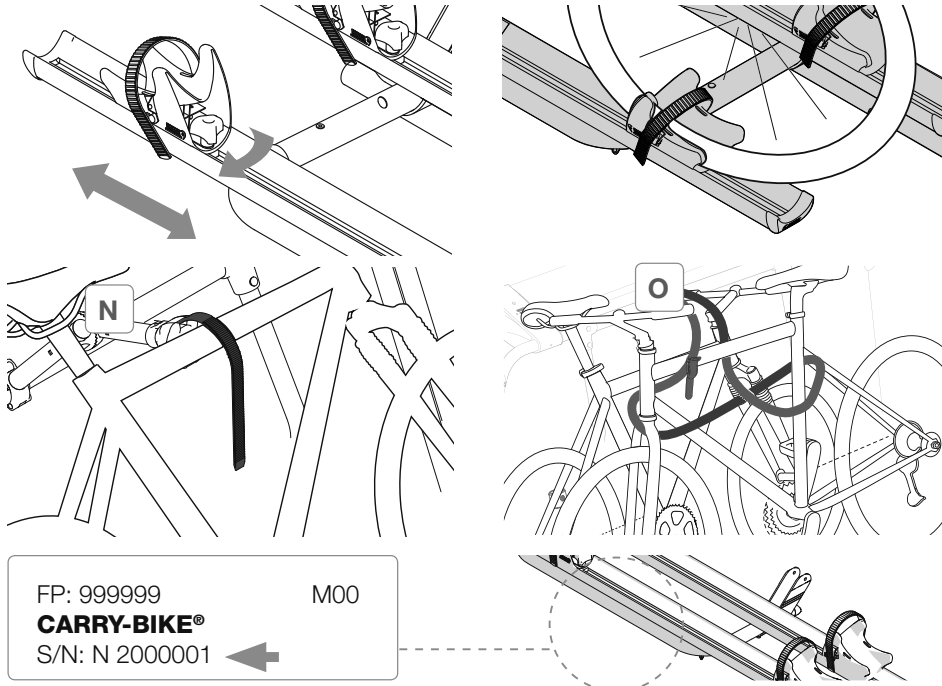

- EN** In case of problems please contact your local dealer indicating the data on the nameplate. Consult our website for spare parts drawing.
- DE** Bei Problemen bitte den Händler kontaktieren und die auf dem Etikett aufgeführten Daten mitteilen. Auf der Homepage finden Sie die Explosionszeichnung
- FR** En cas de problème, contacter le revendeur et lui communiquer les informations reportées sur la plaquette. Consulter le site Internet pour une vue éclatée des pièces de rechange.
- ES** En caso de cualquier problema, ponerse en contacto con su distribuidor local facilitando los datos sobre la placa. Consultar el sitio web para el despiece de los repuestos.
- IT** In caso di problemi contattare il rivenditore di zona, comunicando i dati riportati sulla targhetta. Consultare il sito web per l'esplosione ricambi.
- NL** Raadpleeg uw lokale dealer in geval van problemen onder vermelding van de gegevens op het typeplaatje. Raadpleeg de website voor de detailtekening met onderdelen.
- SV** Vid problem, kontakta en lokal återförsäljare och uppge uppgifterna som står på typskylten. Gå till webbplatsen för en sprängskiss över reservdelar.
- DA** Kontakt din lokale forhandler i tilfælde af problemer, og angiv oplysningerne på skiltet. Rådfør med webstedet for listen over reservedele.
- NO** Ved problemer ta kontakt med den lokale forhandleren, og oppgi informasjonen på merkeplaten. Se nettsidene for detaljert tegning av reservedelene.
- FI** Mikäli ilmenee ongelmia, ota yhteys alueen jälleenmyyjään ja ilmoita kilvessä olevat tiedot. Varaosien irto-osakuvat löytyvät nettisivuilta.
- PT** Em caso de problemas contactar o revendedor de zona, comunicando os dados gravados na chapa. Consultar o site web para a vista explosiva das peças sobresselentes.



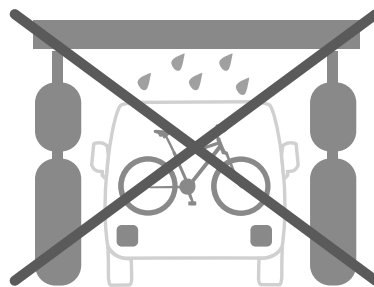
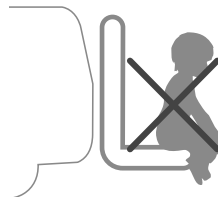
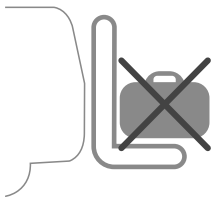
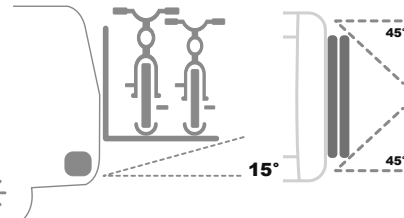
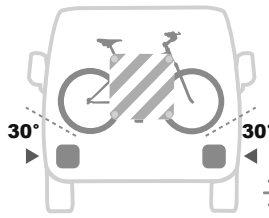
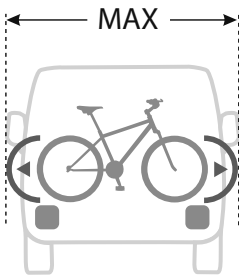
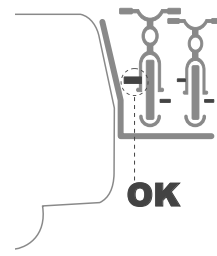
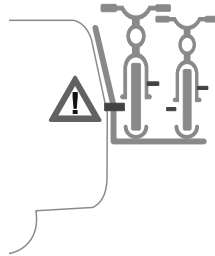
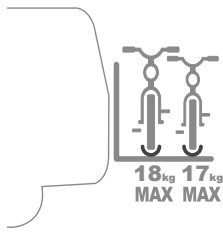



## EN

Read the following instructions and warnings carefully; failure to observe these installation and usage instructions as well as the laws for driving in the relevant country may cause severe harm or damage for which the manufacturer declines all responsibility. Before installation, ensure compatibility with the vehicle on which the product must be installed.

Checking that the wall/rear door is sufficiently solid and suitable for guaranteeing the resistance of the anchoring points is always mandatory. If not, strength and compliance with the maximum load indicated in the instructions are not guaranteed and it will be necessary to reinforce these points.

After having positioned the Carry-Bike on the rear axle of the vehicle, the normal weight distribution on both axles would be modified. This variation must not exceed the maximum permissible axle load.

Never exceed the maximum permitted length and the total weight of the full-load vehicle.

Make sure that loading occurs following a correct weight distribution; it must be uniformly distributed (the heaviest bike must be placed near the wall of the vehicle) to ensure better stability.

Always give warnings about the presence of the Carry-Bike on your vehicle, using a clearly signal for leaning loads and, in case of limited rear visibility, use the additional rear-view mirrors.

Take into account the presence of the Carry-Bike, paying attention during driving and especially during reversing manoeuvres, particularly if you have parking assist system.

In case of use of the bike carrier with tow make sure that the tow hook is always accessible and the corner mobility of the tow is guaranteed (volume measuring DIN 74058).

Check periodically the bicycle rack to make sure it is firmly attached, especially during the first kilometers of after long trips to avoid damages of the Carry-Bike.

While assembling, pay attention not to close the rear door if the screws of the lower bar of the Carry-Bike are not tightened, the body of the vehicle could be damaged

During Carry-Bike installation, verify that there is enough distance between handlebars and/or pedals and the vehicle's rear windows in order to avoid any damages of the window van; do not leave accessories attached (bag seats, baskets, etc) because vibrations could disengage bikes.

In some cases, the rear windscreen wiper may not work due to the presence of bicycles. Be aware of the brush radius before operating the windscreen wiper.

On this type of Carry-Bike-Covers are not allowed (Bike Cover).



- EN Warranty Fiamma**  
In case of defects with regards to materials and manufacturing, the customer is entitled to the warranty in accordance with local laws and regulations of the country in which the product was purchased.
- DE Garantie Fiamma**  
Im Falle einer Mangelhaftigkeit der Ware, kann der Verbraucher unter den erforderlichen Voraussetzungen gegenüber dem Verkäufer von dem Garantieanspruch zu den festgelegten Bedingungen gemäss den lokalen Rechtsvorschriften Gebrauch machen.
- FR Garantie Fiamma**  
En cas d'un défaut de conformité du produit, le consommateur pourra faire valoir ses droits de recours en garantie selon les modalités prévues par les dispositions légales locales, pour autant que les conditions de recours soient satisfaites.
- ES Garantía Fiamma**  
En caso de fallos o defectos de material y de fabricación, el cliente puede hacer valer la garantía de acuerdo con las leyes y reglamentaciones del país en el que el producto haya sido comprado.
- IT Garanzia Fiamma**  
In caso di difetto di conformità dei beni, il consumatore potrà far valere nei confronti del venditore la garanzia secondo le modalità previste dalle disposizioni di legge locali, ove ne ricorrano i presupposti.
- NL Fiamma garantie**  
In het geval van gebrek aan overeenstemming van de goederen kan de consument zich beroepen op de wettelijke garantie ten opzichte van de verkoper, zoals vastgelegd in de plaatselijke regelgeving, indien de omstandigheden dit rechtvaardigen.
- SV Fiamma-garanti**  
Vid brister på varorna kan konsumenterna åberopa garantin i enlighet med lokal lagstiftning, om omständigheterna berättigar detta.
- DA Garanti Fiamma**  
I tilfælde af defekter, hvad angår materialer og fremstilling, er forbrugeren berettiget til forhandlergarantien i henhold til lokale love og bestemmelse i det land, hvori produktet blev fremstillet.
- NO Fiammas garanti**  
I tilfelle av defekter ved varene kan forbrukeren fremme sine rettigheter i henhold til garantien overfor forhandleren, i henhold til de reglene som er fastsatt i lokale lover, der forutsetningene for dette er til stede.
- FI Fiamma-takuu**  
Jos tuotteiden vaatimustenmukaisuudessa havaitaan puutteita, kuluttaja voi vaatia myyjältä takuun mukaisia oikeuksia paikallisen lainsäädännön puitteissa, mikäli vaatimus on perusteltu.
- PT Garantia Fiamma**  
Em caso de defeito de conformidade dos bens, o consumidor poderá fazer valer, em relação ao vendedor, a garantia segundo as modalidades previstas pelas disposições de lei locais, se existirem os pressupostos para tal.

**RAIL PREMIUM S**

Item No. 98656-656

**PLASTIC SIGNAL**

Item No. 98782-005

**CABLE-LOCK**

Item No. 98656-338

**BIKE-BLOCK PRO S****ALU SIGNAL**

Item No. 98782-010

**LICENCE PLATE CARRIER**

Item No. 06146-01-

**BIKE-BLOCK PRO S D****BIKE FRAME ADAPTER**

Item No. 06602-01-



fiamma.com

**Fiamma S.p.A. - Italy**  
Via San Rocco, 56  
21010 Cardano al Campo (VA)

MO\_IS\_98690-243\_revL

All rights reserved.  
**Fiamma S.p.A.**  
reserves the right to modify at any time,  
without notice, prices, materials,  
specifications and models or to cease  
production of any model.